

# Citia™ Standard BOS and Citia™ Standard<sup>Plus</sup> BOS Stair Lifts

## Unit Dimensional Drawing

### SPECIFICATIONS

**Rated Load:** 300 lbs (135kg)

**Speed:** 19 fpm (.10 ms)

**Travel:** 32' max. (9.75m) (track length)

**Power Supply:** 115 VAC, 60 Hz, 3-wire grounded outlet

**Incline limits:** 25° to 45° (and up to 55° with local jurisdiction approval)

**ETL and cETL Listed**

### STANDARD EQUIPMENT

**Drive System:** Rack and pinion

**Motor:** .5 hp, 24 VDC with self-locking drive system, reversible

**Control System:** Battery Operated System (BOS) with SoftStart / SoftStop control board with diagnostic LED's with two 12-volt maintenance free batteries.

**Charging Stations:** Integrated charge stations at top and bottom, charge fault alarm, low battery indication through audible alarm, reduced speed and LED indication

**Controls:** Constant pressure handheld pendant control and 2 wireless remote controls (infra-red)

**Brake:** Self-locking worm gear

**Track:** 5 1/2" wide extruded aluminum

**Track Length:** 16' stock or custom cut

**Track Finish:** Unfinished aluminum

**Upholstery:** Citia Standard – unupholstered

Citia Standard Plus – Desert sand fabric or tan vinyl over lightly padded seat and seat back

**Seat:** 18 1/4" wide seat with two fixed arms, seat belt, 70° locking swivel at upper and lower landings

### Safety Devices:

Footrest obstruction sensor

Swivel seat cut-off switch

Final limits

Seat belt

**Warranty:** Five years on drive train and two years on all component parts

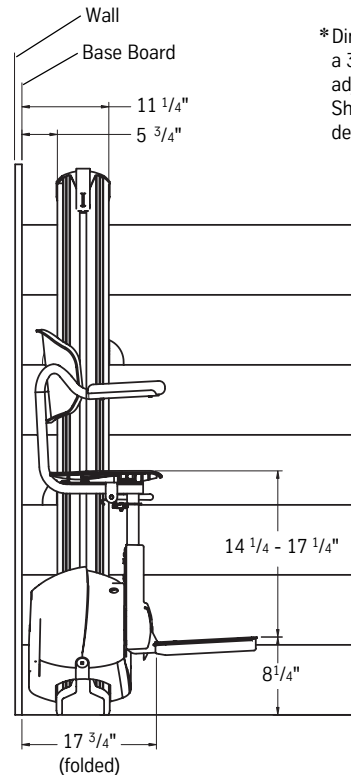

END VIEW

\*Dimensions are based on a 35° stair angle and standard seat heights with a 3 1/4" top track extension. The seat height at the lower landing can be adjusted by the dealer to heights between 23" - 26". See Measurement Sheet - Order Form for details on calculating the track extension based on desired seat heights at the top and lower landings.

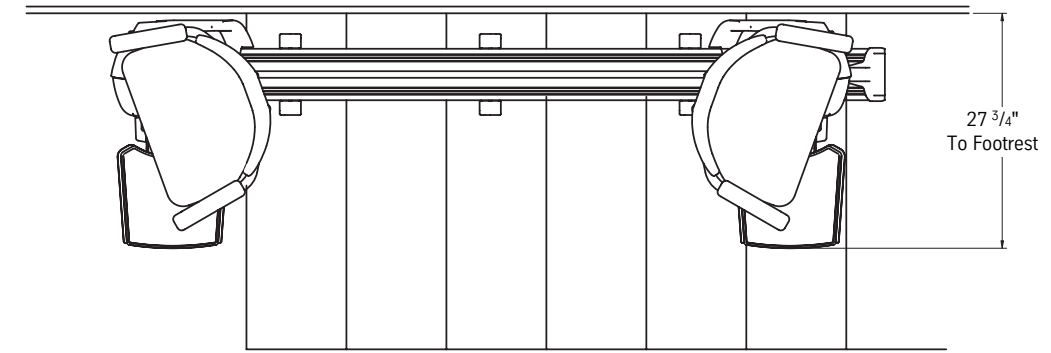

TOP VIEW

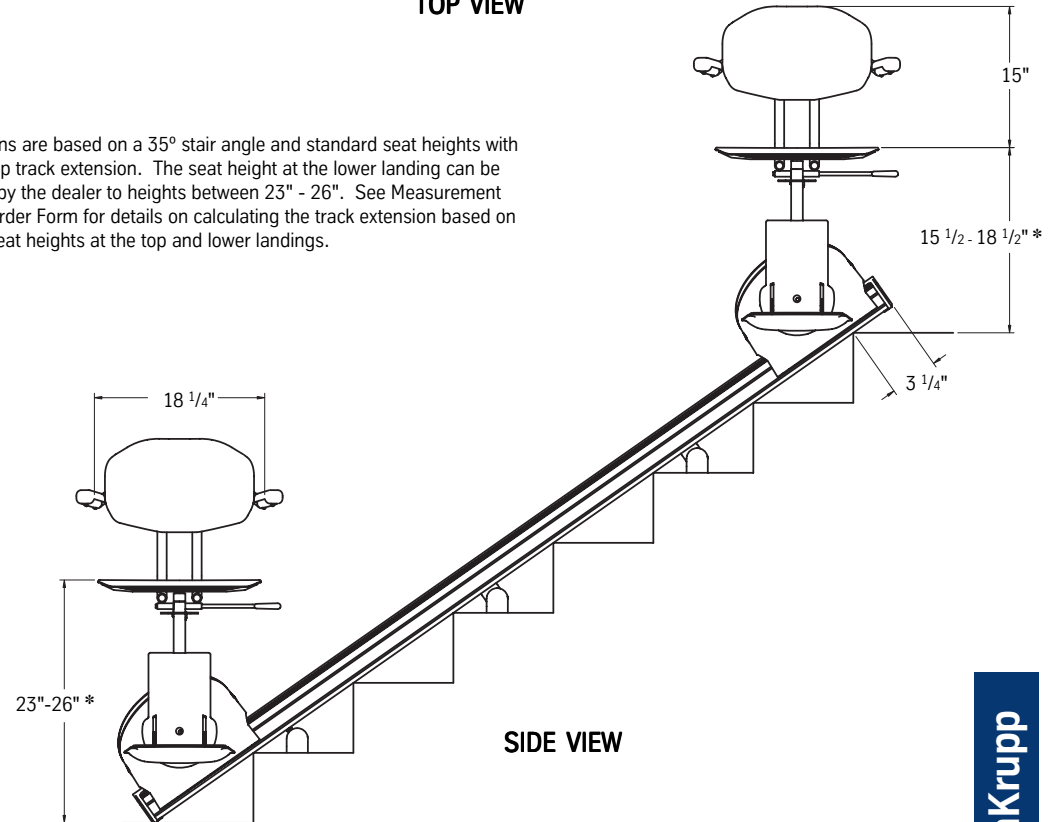

**ThyssenKrupp Access**  
Accessibility Division



ThyssenKrupp